



Photo 1

Photo 2

Photo 1: LED 025 with on/off switch and magnet fixing  
Photo 2: LED 025 with movement sensor and screw fixing

- **Wide voltage range**
- **Integrated power unit**
- **Daisy chain**
- **Long-lived and maintenance-free by LED technology**
- **Magnet or screw fixing**
- **On/off switch or movement sensor**

The lamp series LED 025 is suitable for all types of panels and enclosures, especially where space is at a premium. The lamps have a very long service life thanks to the use of LED technology. They are available with powerful non-slip rubberized magnets allowing them to be quickly positioned in any steel enclosure. Alternatively they can be fixed mechanically. The power output allows up to 10 lamps to be connected to each other (daisy chain). Both the power input and output connectors snap lock into their sockets. With the integrated power unit and the plugs the lamp can quickly be connected.

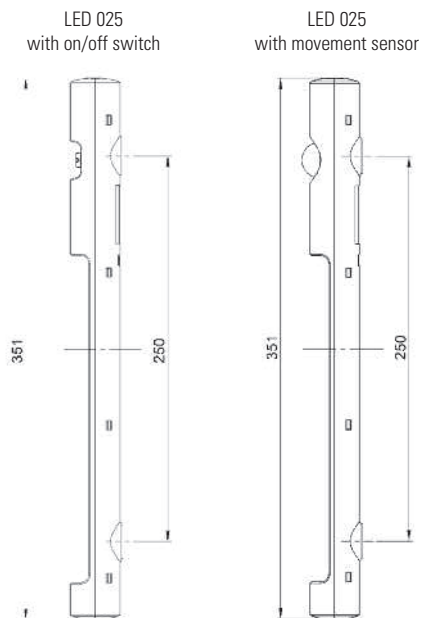

### Technical Data

<b>Power consumption</b>	max. 5W
<b>Luminosity</b>	290Lm at 120° (870Lm at 360° or equivalent 75W light bulb)
<b>Lamp type</b>	LED, angle of radiation 120° light color: daylight, color temperature: 6,500K
<b>Service life</b>	60,000h at 20°C (68°F)
<b>Connection</b>	2-pole connector with snap lock AC: max. 2.5A / 240VAC, color: white DC: max. 2.5A / 60VDC, color: blue
<b>Mounting</b>	magnet fixing or screw fixing, M5, 250mm centers
<b>Casing</b>	plastic, transparent
<b>Dimensions</b>	see drawings
<b>Operating / Storage temperature</b>	-30 to +60°C (-22 to +140°F) / -40 to +85°C (-40 to +185°F)
<b>Operating / Storage humidity</b>	max. 90% RH (non-condensing)
<b>Protection type / Protection class</b>	IP20 / II (double insulated)
<b>Approvals</b>	UL File No. E234324, VDE intended

**Important note:** Connectors and cables for electrical connection are not included in the delivery. These parts need to be ordered separately, see Accessories on next page.

Art. No. magnet fixing	Art. No. Screw fixing	Operating voltage	Switch	Weight (approx.)
02540.0-00	02540.0-01	100-240VAC, 50/60Hz (min. 90VAC, max. 265VAC)	on/off light switch	0.2kg
02540.1-00	02540.1-01	24-48VDC (min. 20VDC, max. 60VDC)	on/off light switch	0.2kg
02541.0-00	02541.0-01	100-240VAC, 50/60Hz (min. 90VAC, max. 265VAC)	PIR movement sensor <sup>1</sup>	0.2kg
02541.1-00	02541.1-01	24-48VDC (min. 20VDC, max. 60VDC)	PIR movement sensor <sup>1</sup>	0.2kg

<sup>1</sup> approx. 5 min. fixed switch-on duration

## Connection cable with female connector and open end



Photo: Connection cable, Art. No. 244356

Art. No.	Model	Length	Voltage type	Color	Use for	Approvals <sup>2</sup>
244356	connection cable 2x1.5mm <sup>2</sup> with female connector	2.0m	AC	connector: white; cable: white	power input	VDE
244357	connection cable 2xAWG 16 with female connector	2.0m	AC	connector: white; cable: white	power input	VDE + UL
244360	connection cable 2x1.5mm <sup>2</sup> with female connector	2.0m	DC	connector: blue; cable: white	power input	VDE
244361	connection cable 2xAWG 16 with female connector	2.0m	DC	connector: blue; cable: white	power input	VDE + UL

<sup>2</sup> applies only to the individual components (cable and connectors)

## Extension cable with 2 connectors for daisy chain connection



Photo: Extension cable, Art. No. 244358

Art. No.	Model	Length	Voltage type	Color	Use for	Approvals <sup>2</sup>
244358	extension cable 2x1.5mm <sup>2</sup> with 2 connectors	1.0m	AC	connectors: white; cable: white	daisy chain	VDE
244359	extension cable 2xAWG 16 with 2 connectors	1.0m	AC	connectors: white; cable: white	daisy chain	VDE + UL
244362	extension cable 2x1.5mm <sup>2</sup> with 2 connectors	1.0m	DC	connectors: blue; cable: white	daisy chain	VDE
244363	extension cable 2xAWG 16 with 2 connectors	1.0m	DC	connectors: blue; cable: white	daisy chain	VDE + UL

<sup>2</sup> applies only to the individual components (cable and connectors)

## Female / Male connectors



Photo: Female connector, Art. No. 264057



Photo: Male connector, Art. No. 264058

Art. No.	Model	Voltage type	Color	Use for	Approvals
264057	female connector	AC	white	power input	VDE + UL
264058	male connector	AC	white	power output	VDE + UL
264059	female connector	DC	blue	power input	VDE + UL
264060	male connector	DC	blue	power output	VDE + UL

## Connection Example

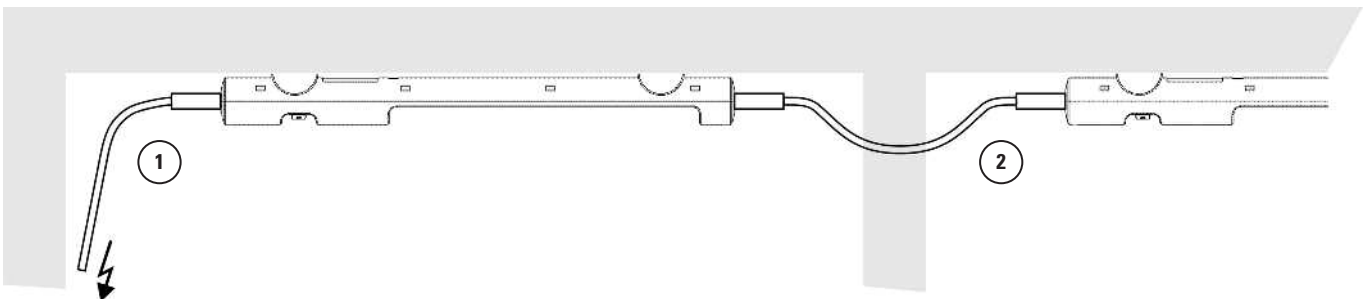

This illustration shows the LED 025 lamp in a daisy chain application. The lamps are conveniently connected via quick connection plugs – up to 10 lamps max. can be daisy-chained this way. The snap lock connectors ensure a stable electrical connection even if subjected to heavy vibration. The connection example shows a 230VAC application, using the following cables: connection cable with female connector, Art. No. 244356 (1); daisy chain extension cable with 2 connectors, Art. No. 244358 (2).

Female/male connectors are also available to assemble cables in non-standard lengths.