



- High air output
- Long service life
- Ball bearing fans
- Ready for connection
- Optical function indicator

Compact high performance fan tray for enforced circulation of air in switch and server enclosures and for concerted cooling of 19" component groups. Natural convection is improved and the formation of localised hot pockets is avoided. Also available with integrated thermostat (see photo).



Technical Data

Axial fans, ball bearing	service life 50,000h at 25°C (65% RH) fan body aluminium, rotor plastic
Material	front panel aluminium, bright anodised casing steel sheet, electrogalvanized
Optical indicator	integrated in front panel
Connection	appliance power inlet on rear of casing, plug included
Fitting position	vertical airflow (air outlet up)
Operating / Storage temperature	-45 to +70°C (-49 to +158°F)
Operating / Storage humidity	max. 90% RH (non-condensing)
Protection type / Protection class	IP20 / I (earthed)
Approvals	UL File No. E234324

Use in 19" enclosures:

We recommend using the fan tray without integrated thermostat in combination with our dual thermostat (ZR 011 Art. No. 01176.0-00) for regulating temperature in electronic enclosures and for protection against overheating due to possible fan failure. The dual thermostat regulates the operation of the fan tray and – when connected to a signal device – also triggers an early warning if the enclosure interior temperature rises above a set limit.

When using a fan tray with integrated thermostat, the use of an additional thermostat (KTS 011 Art. No. 01141.0-00) provides the extra safety of activating a signal device.

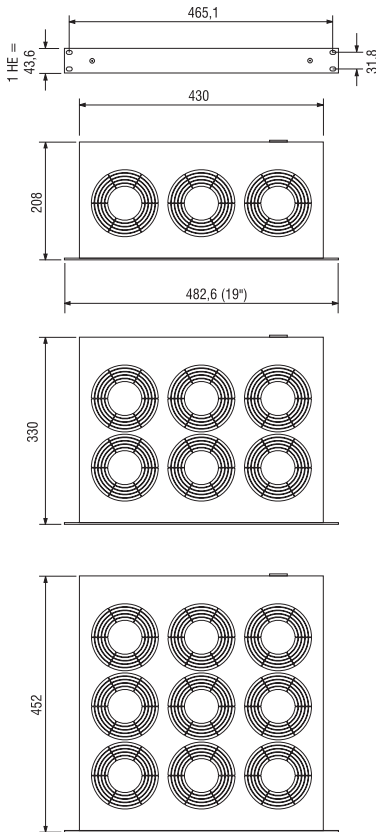

Art. No.	Model	No. of fans	Operating voltage	Air flow, free flow	Power consumption	Average noise level (DIN EN ISO 4871)	Speed (rpm ⁻¹)	Impact pressure	Weight (approx.)
01930.0-00	without thermostat	3	230VAC, 50Hz	486m ³ /h	45W	55db (A)	2600 min ⁻¹ (50Hz)	74Pa	3.0kg
01930.1-00	with thermostat 0 to +60°C	3	230VAC, 50Hz	486m ³ /h	45W	55db (A)	2600 min ⁻¹ (50Hz)	74Pa	3.4kg
01940.0-00	without thermostat	6	230VAC, 50Hz	972m ³ /h	90W	57db (A)	2600 min ⁻¹ (50Hz)	74Pa	5.3kg
01940.1-00	with thermostat 0 to +60°C	6	230VAC, 50Hz	972m ³ /h	90W	57db (A)	2600 min ⁻¹ (50Hz)	74Pa	5.7kg
01950.0-00	without thermostat	9	230VAC, 50Hz	1458m ³ /h	135W	58db (A)	2600 min ⁻¹ (50Hz)	74Pa	7.8kg
01950.1-00	with thermostat 0 to +60°C	9	230VAC, 50Hz	1458m ³ /h	135W	58db (A)	2600 min ⁻¹ (50Hz)	74Pa	7.9kg
01931.0-00	without thermostat	3	120VAC, 60Hz	576m ³ /h	45W	55db (A)	2900 min ⁻¹ (60Hz)	88Pa	3.0kg
01931.1-00	with thermostat 0 to +60°C	3	120VAC, 60Hz	576m ³ /h	45W	55db (A)	2900 min ⁻¹ (60Hz)	88Pa	3.4kg
01941.0-00	without thermostat	6	120VAC, 60Hz	1152m ³ /h	90W	57db (A)	2900 min ⁻¹ (60Hz)	88Pa	5.3kg
01941.1-00	with thermostat 0 to +60°C	6	120VAC, 60Hz	1152m ³ /h	90W	57db (A)	2900 min ⁻¹ (60Hz)	88Pa	5.7kg
01951.0-00	without thermostat	9	120VAC, 60Hz	1728m ³ /h	135W	58db (A)	2900 min ⁻¹ (60Hz)	88Pa	7.8kg
01951.1-00	with thermostat 0 to +60°C	9	120VAC, 60Hz	1728m ³ /h	135W	58db (A)	2900 min ⁻¹ (60Hz)	88Pa	7.9kg