



- **High DC breaking capacity**
- **Low hysteresis**
- **Adjustable temperature**
- **Change-over contact**
- **Clip fixing**

Electronic thermostat for regulating high performance 24VDC equipment. Heating or cooling appliances as well as signal devices can be switched via the potential free change-over contact. In comparison to mechanical thermostats, the ET 011 has a low hysteresis making the switching point and setting accuracy more precise.



Technical Data

Switch temperature difference	approx. 3K
Sensor element	PTC
Contact type	change-over
Service life	> 100,000 cycles
Max. switching capacity	28VDC, 16A
Max. inrush current	16ADC
Connection	5-pole terminal, clamping torque 0.5Nm max.: rigid wire 2.5mm ² stranded wire (with wire end ferrule) 1.5mm ²
Mounting	clip for 35mm DIN rail, EN 60715
Casing	plastic according to UL94 V-0, light grey
Dimensions	67 x 50 x 46mm
Weight	approx. 80g
Fitting position	vertical
Operating / Storage temperature	0 to +60°C (32 to +140°F) / -45 to +80°C (-49 to +176°F)
Operating / Storage humidity	max. 90% RH (non-condensing)
Protection type	IP20
Approvals	-

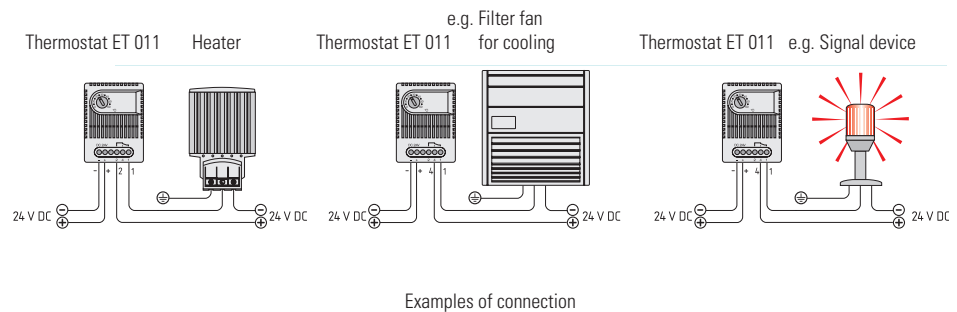
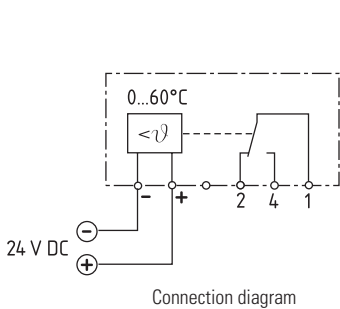
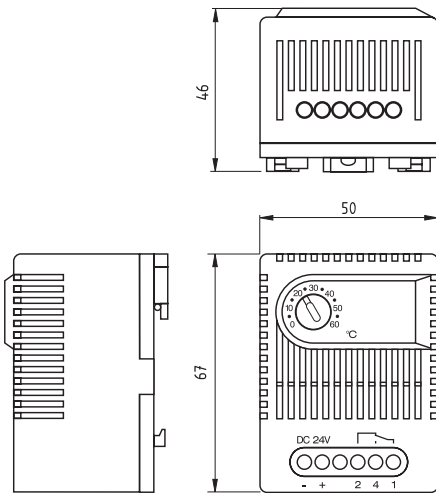

Art. No.	Operating voltage	Setting range
01190.0-00	24VDC (20-28VDC)	0 to +60°C